

Design and Construction of an IoT-Based Coconut Milk Processing Machine to Become VCO

Mahmud Idris ^{a,*}, Yudhi Agussationo ^b, Sandi Yudha Barrizaqi ^c

^a Program Studi Teknik Elektronika, Politeknik Jambi, Jl. Lingkar Barat II Lr. Veteran Kel. Bagan Pete, Kec. Alam Barajo, Kota Jambi, Indonesia

^b Program Studi Teknik Listrik, Politeknik Jambi, Jl. Lingkar Barat II Lr. Veteran Kel. Bagan Pete, Kec. Alam Barajo, Kota Jambi, Indonesia

^c Program Studi Teknologi Rekayasa Pemeliharaan Alat Berat, Politeknik Jambi, Jl. Lingkar Barat II Lr. Veteran Kel. Bagan Pete, Kec. Alam Barajo, Kota Jambi, Indonesia

INFO ARTIKEL

Riwayat Artikel:

Diterima 17 Oktober 2025

Diterima setelah direvisi 20 November 2025

Disetujui 20 November 2025

Kata kunci:

VCO Processing

Coconut Milk

Kontrol IoT

ESP 32

Abstract-Virgin Coconut Oil (VCO) is a processed product from coconut flesh in the form of a clear, tasteless liquid with a distinctive coconut aroma. VCO is obtained through processing coconut milk with several methods, namely the gradual cooking method, the oil fishing method, and the fermentation method. Of these three methods, gradual heating is the most commonly used. This process requires a stable heating device to produce quality VCO. Therefore, to maintain the stability of the heating, precise control is required in the gradual heating method. The heating device is designed to streamline the processing process with an IoT-based control system. This VCO processing device is designed with a temperature control system using an NTC sensor with a high accuracy of $\pm 1.5^{\circ}\text{C}$ to ensure temperature stability during the coconut milk heating process using a dual-core ESP32 microcontroller that has WiFi connectivity features, thus enabling integration into the Internet of Things (IoT) system for remote monitoring. For the heating process, this device is equipped with a 220V 400W heating element controlled by a Solid State Relay (SSR), so that the temperature can be precisely controlled in the range of 60–90°C.

Intisari-Virgin Coconut Oil (VCO) adalah produk olahan dari daging kelapa yang berbentuk cairan jernih, tidak berasa, dan memiliki aroma khas kelapa. VCO diperoleh melalui pengolahan santan kelapa dengan beberapa metode, yaitu metode pemanasan bertahap, metode pemancingan minyak, dan metode fermentasi. Dari ketiga metode tersebut, pemanasan bertahap merupakan cara yang paling umum digunakan. Proses ini memerlukan alat pemanas yang stabil agar menghasilkan VCO berkualitas. Oleh karena itu, untuk menjaga kestabilan pemanas di butuhkan pengontrolan yang tepat dalam metode pemanasan bertahap. Alat pemanas dirancang untuk mengoptimalkan proses pengolahan dengan sistem kontrol berbasis IoT. Alat pengolahan VCO ini dirancang dengan sistem kontrol suhu menggunakan sensor NTC dengan akurasi tinggi $\pm 1.5^{\circ}\text{C}$ untuk memastikan kestabilan suhu selama proses pemanasan santan menggunakan mikrokontroler ESP32 dual-core yang memiliki fitur konektivitas WiFi, sehingga memungkinkan integrasi ke sistem Internet of Things (IoT) untuk pemantauan jarak jauh. dan Untuk proses pemanasan alat ini dilengkapi dengan heater elemen 220V 400W yang dikontrol melalui Solid State Relay (SSR), sehingga suhu dapat dikendalikan secara presisi di kisaran 60–90°C

1. Introduction

Indonesia is one of the countries whose economy is generated from plantations, one of which is coconut plantations [1]. Indonesia is the largest coconut producer in the world with plantations spread almost throughout the archipelago. This potential makes Indonesia a country with an abundant supply of coconut raw materials, both for local consumption and the needs of the processing industry. Coconut plantations in Indonesia not only play a role in meeting domestic needs, but also make a significant contribution to the economy through the export of derivative products, such as coconut oil, coconut milk, and Virgin Coconut Oil (VCO).

According to the Central Statistics Agency (BPS), in 2023 the area of coconut plantations in Indonesia reached more than 3.3 million hectares with production that places Indonesia at the top of the world ranking [2]. This shows that coconuts have a strategic role in supporting food security and the national economy.

The coconut tree is one of the trees that can be used and utilized all parts of the coconut [3]. Coconut fruit, which consists of fiber, shell, flesh, and coconut water, can be used to make various industrial products, such as doormats, brooms, and mattresses [4]. Activated carbon and handicrafts are made from the shell. Coconut trunks can be used as building materials for frames, walls, and roofs. Coconut leaves are used for their fronds to

* Corresponding Author:

E-mail: mahmud@politeknikjambi.ac.id (Mahmud Idris)

make brooms and woven items. Besides being used to make copra, coconut milk, dried grated coconut, vinegar and natadecoco and coconut cream, coconut flesh is also used to make pure oil products such as Virgin Coconut Oil [5].

The wet method involves three consecutive steps: coconut milk production, cream and skim separation, and coconut cream separation. The cream is separated from the coconut milk by gradual heating [6].

Hydrolysis of the peptide bonds in the coconut cream leads to oil formation [7]. If the peptide bonds hydrolyze and cause the emulsion system to become unstable, the oil can escape from the emulsion system. Virgin coconut oil (VCO), produced by the gradual separation of chemical elements through proper processing, is clear and tasteless or odorless [8].

According to Santosa [9], Virgin Coconut Oil (VCO) is a processed product from coconut flesh. It is a clear, tasteless liquid with a distinctive coconut odor. Virgin Coconut Oil contains high levels of medium- and short-chain saturated fatty acids. Benefits of Virgin Coconut Oil (VCO) include increasing the human body's resistance to disease and accelerating the healing process [10]. The use of VCO in processing various products can be classified into three groups: food, pharmaceutical, and cosmetic products [8]. VCO can be produced using fishing, fermentation, enzymatic, and centrifugation methods [11].

Virgin coconut oil (VCO) is made from fresh coconut flesh and is processed at relatively low temperatures. Gradual heating, oil fishing, and fermentation are some of the methods currently widely used to produce VCO [12]. The gradual heating process begins by heating coconut milk to a temperature of 60–90 degrees Celsius [13].

This step-heating machine operates with an electric motor. There are several advantages to using electric motors. One is their ability to operate in relatively small capacities. Electric motors can be easily operated by simply pressing the starter contact [14].

The use of the Internet of Things (IoT) in Indonesia is growing, particularly in agriculture and smart cities. In the agricultural sector, IoT is used to automate irrigation systems, monitor soil moisture, and control water flow in real time to achieve efficient resource use [15]. Meanwhile, in smart city development, the integration of IoT with artificial intelligence (AI) is a potential solution for improving public services, energy management, and city security sustainably [16]. Both studies show that the implementation of IoT not only improves operational effectiveness but also supports Indonesia's digital transformation towards a smarter and more competitive society.

The Internet of Things (IoT) in Virgin Coconut Oil (VCO) processing technology provides innovation opportunities to improve efficiency and product quality consistency. The IoT system allows the VCO extraction process to be carried out automatically by integrating temperature sensors, as well as actuators controlled by microcontrollers and connected to the internet network. Important parameters in this processing process are heating temperature, the duration of gradual heating of the oil can be monitored and controlled in real-time. Data obtained from sensors will be stored on a cloud-based IoT platform so that it can be analyzed to maintain product quality and optimize the production process. With VCO processing technology, it no longer depends entirely on manual skills, but can be done automatically, efficiently, and safely. According to Gubbi, IoT enables the development of intelligent systems that connect physical devices with digital services to support automation and data-driven decision-making [17].

This study uses a gradual heating method to process coconut milk into VCO without using chemicals. This process is carried out with several IoT-based machine tools. The machines used consist of various equipment combined in one mini factory that has the capacity to reach the IKM scale. Where the machines used include a 1-phase AC electric motor with a motor speed of 2800 rpm and 125 watts of power and uses a voltage of 220v as the main drive and uses a gearbox with a ratio of 1:30 to change the torque or speed of the motor through the addition of mechanical gears to increase torque and reduce speed and use a furnace system for heating coconut milk and As the core of the system control, an Arduino ESP32 microcontroller is used to be integrated into the IoT system, which is supported by a Thermocouple MAX6675 temperature sensor to detect heating temperatures with high accuracy. It is hoped that processed coconut products can increase added value that encourages the growth of the domestic downstream coconut fruit industry, especially in Jambi province

2. Methodology

In this study, the method used is an empirical method, namely collecting data from library study sources, and conducting observations on the VCO oil making machine with a gradual heating system. Next, the design of the shape and manufacture (assembly) of the components of the VCO oil making machine from coconut milk is carried out, which is realized in one tangible form in the form of a gradual heating machine for coconut milk into VCO oil that operates continuously. The working principle of this tool is to heat coconut milk gradually until it becomes VCO oil continuously. Where the coconut milk will always be stirred continuously in the heating container until the coconut milk becomes VCO oil and then after the coconut milk becomes VCO, the VCO oil is filtered to make dirt/dregs from the heating process. The materials used in making this VCO oil are from old and fresh coconut flesh. During the VCO making process in this activity no chemicals are used at all.

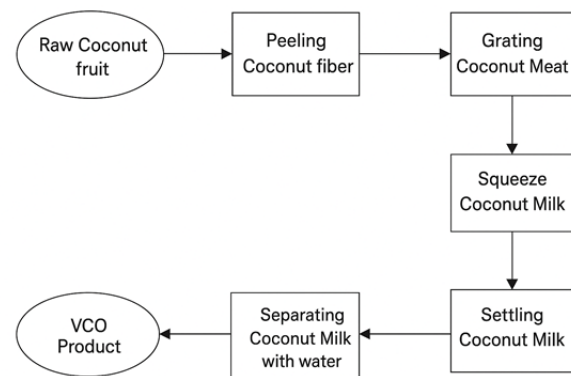

Figure 1. Flow diagram of the process of processing coconut into VCO oil

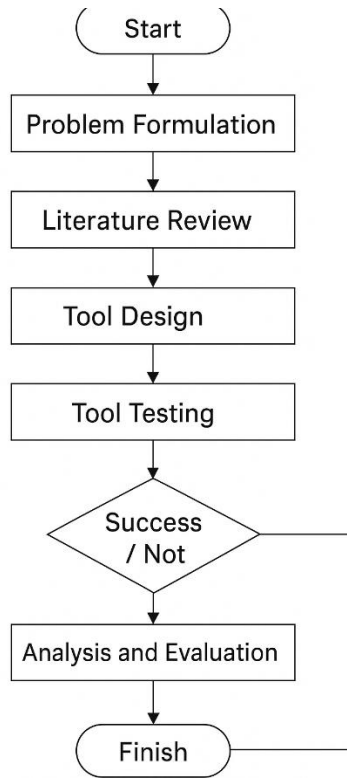

Figure 2. Flowchart of The Research Process

The Internet of Things (IoT) connects devices via the internet. Data processing devices collect, analyze, and share data. This technology helps manage resources in the processing of coconut milk into VCO. Sensors measure the temperature of the step heater. Data processing allows users to obtain the information they need to ensure the device is working properly and efficiently.

2.1. Sensor Thermocouple MAX6675

The Type-K Thermocouple temperature sensor with the MAX6675 module is a device capable of converting changes in environmental temperature into digital electrical signals. This sensor is usually used to measure temperatures in industrial machines, heating furnaces, and high-temperature research processes. However, in this final project, the MAX6675 Thermocouple sensor is used to measure the temperature in the gradual heating process of coconut milk to produce Virgin Coconut Oil (VCO), thus enabling continuous and precise temperature monitoring. This approach is in line with studies in the field of MAX6675-based temperature monitoring, such as IoT-based temperature monitoring systems that are capable of achieving measurement differences of less than 1 °C [18].



Figure 3. Thermocouple Type-K temperature sensor with MAX6675 module.

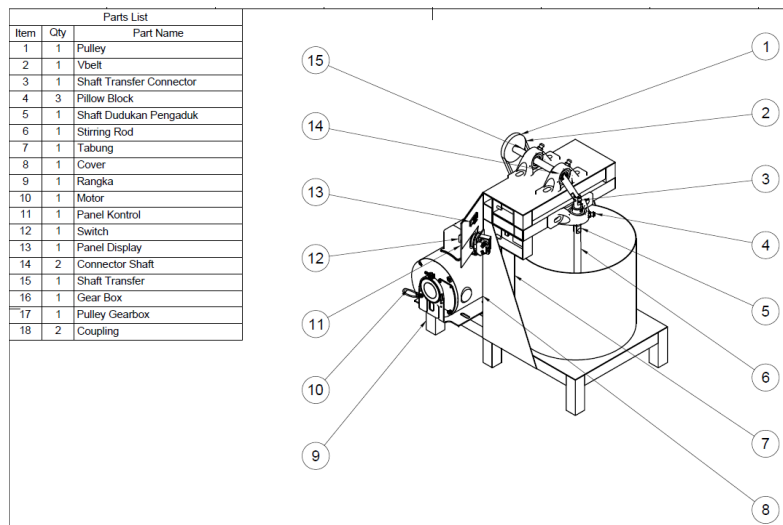

Figure 4. Design of a Staged Heating Equipment for Coconut Milk Cream into VCO

2.2. Mikrokontroler ESP32

ESP32 Microcontroller A data processing device equipped with integrated Wi-Fi and Bluetooth modules, thus supporting the implementation of Internet of Things (IoT) based systems. ESP32 is widely used in various applications, ranging from monitoring systems, automatic control, to smart devices because it has high performance, low power consumption, and a relatively affordable price. In this study, ESP32 is used as the main controller to read temperature data from the Thermocouple MAX6675 sensor and process and send data in real-time. This allows the process of monitoring the temperature in the gradual heating of coconut milk to produce Virgin Coconut Oil (VCO) to be carried out more efficiently and in an integrated manner [19].



Figure 5. Mikrokontroler ESP32.

2.3. Heater

Heater An electric heating device that converts electrical energy into heat energy through a heating element. Heaters are used in various applications such as ovens, furnaces, incubators, and food processing that require controlled temperatures. In this study, a heater is used as a heat source in the gradual heating process of coconut milk to produce Virgin Coconut Oil (VCO). The use of a heater provides better temperature stability than heating using direct heat, so the quality of the resulting VCO can be better maintained [20].



Figure 6. Heater.

2.4. Power supply

A power supply is a device that functions to provide and stabilize the source of electrical energy to operate electronic circuits. In general, a power supply converts AC voltage from the electrical network into DC voltage that suits the needs of components, such as microcontrollers, sensors, and actuators. In this study, a power supply is used to supply electrical energy to a temperature measurement system consisting of a MAX6675 Thermocouple sensor, an ESP32 microcontroller, and a Heater as a heating element. With a stable power supply, the system can work optimally and reduce the risk of data reading errors due to voltage fluctuations [21].



Figure 7. Power supply

2.5. Single-phase electric motor

A single-phase electric motor is a type of alternating current (AC) motor that is widely used in household appliances and small-scale industries because its power source is easily obtained from the PLN electricity network. This motor works by utilizing a rotating magnetic field generated by a single-phase electric current, and is usually equipped with a capacitor to help produce initial torque. In this study, a single-phase motor is used as a mechanical drive in the Virgin Coconut Oil (VCO) manufacturing process system, specifically to help stir the coconut milk during gradual heating so that the heat can be evenly distributed. By using a single-phase motor, the heating process becomes more homogeneous so that the quality of the resulting VCO is better [22, 23].



Figure 8. Single-Phase Electric Motor

3. Results and Discussion

The result of this research is the design and construction of an IoT-based device for processing coconut milk into Virgin Coconut Oil (VCO) using a multi-stage heating method. The developed device consists of several main components: a MAX6675 thermocouple temperature sensor, an ESP32 microcontroller, a 400W electric heater, a single-phase electric motor with a gearbox, and a Solid State Relay (SSR)-based power supply and control system.

The device consists of two main parts:

1. **Mechanical System** The main components of the mechanical system are shown in the parts list of the machine design (engineering drawings are included in the design document). These components include:
 - Pulleys, V-belts, and gearboxes for the power transmission system.
 - Single-phase electric motor (125 W, 220 V, 2800 rpm) as the main drive.
 - Transfer shaft, stirrer stand shaft, and stirring rod for the coconut milk stirring mechanism.
 - Heating tube, support frame, and cover as the process container.
 - Pillow block, coupling, and connector shaft to support stable mechanical movement.
2. **Electronic and Control System**
 - ESP32 microcontroller as the control center with Wi-Fi connectivity.
 - Temperature sensor (NTC/Thermocouple MAX6675) to detect the heating process temperature.
 - An electric heater (400 W) serves as the heat source with a relay/SSR module as the controller.
 - The control panel is equipped with switches, fuses, a PCB, and a display for monitoring.

The device is designed to maintain a heating temperature of 60–90°C with a stability of $\pm 1.5^\circ\text{C}$. An electric motor integrated with the stirrer maintains the homogeneity of the coconut milk during the heating process, ensuring a more even separation of the oil from the cream. Temperature data can be monitored in real time via Wi-Fi connectivity on the ESP32, which is connected to a cloud-based IoT platform.

With this design, the VCO production process can be more efficient and automated, resulting in a product of consistent quality. Observations show that the resulting VCO is clear, odorless, and tasteless, meeting general VCO quality standards.

The design and construction of an IoT-based coconut milk processing machine for Virgin Coconut Oil (VCO) integrated with automatic temperature control technology and a gradual heating system ensures a stable process for converting coconut milk into VCO. The MAX6675 thermocouple sensor used has an accuracy of $\pm 1.5^\circ\text{C}$, consistent with Hidayat & Nurhadi's findings that this sensor is effective in IoT-based temperature monitoring systems [18]. Maintaining a stable temperature allows for optimal oil separation from the coconut cream, resulting in clear VCO that meets quality standards.

The use of a single-phase electric motor with a mechanical stirring system plays a crucial role in maintaining the homogeneity of the coconut milk during heating. Even heat distribution in food processing can improve the quality of the final product [22]. Unlike manual methods, this automated system reduces reliance on labor skills while increasing the consistency of production results.

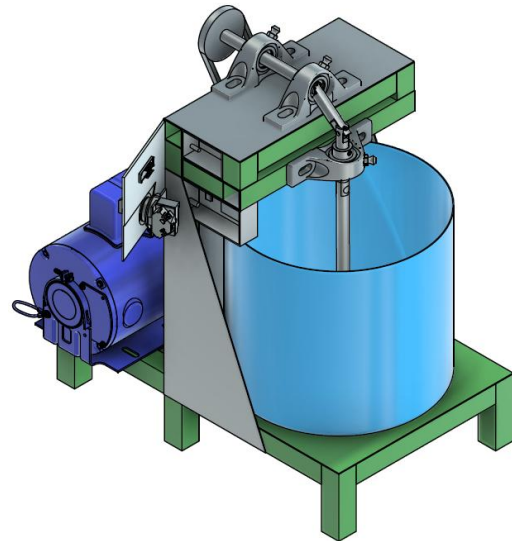

Figure 9. Coconut Processing Equipment To Make VCO Oil

The integration of an ESP32 microcontroller with IoT connectivity enables real-time temperature monitoring through a cloud-based platform. This feature aligns with the trend of digitalization in the food industry [24], where IoT has been shown to improve operational efficiency and enable remote control. Thus, this design not only improves technical efficiency but also opens up opportunities for the development of smart monitoring-based industrial systems in the agro-industrial sector [24].

However, this research still has limitations. It is still limited to the design and initial trials stage on a small scale (mini plant), so the system's effectiveness on an industrial production scale cannot be verified. Furthermore, this study does not include laboratory analysis of the chemical content and nutritional quality of the resulting VCO. This is crucial for product quality to be comparable with international standards such as the APCC Standards for VCO.

Future developments could focus on:

1. Testing to assess the device's performance under industrial production conditions.
2. Integrating additional humidity and viscosity sensors to monitor other parameters that affect VCO quality.
3. Developing an IoT-based application that not only displays temperature data but also performs predictive analysis to optimize the process.
4. Testing VCO quality through laboratory analysis, including moisture content, free fatty acid content, and fatty acid profile.

With further development, this device has the potential to become an effective solution for small and medium coconut processing industries (SMEs) in Indonesia, particularly in areas with abundant coconut raw materials, such as Jambi Province.

4. Conclusion

This research designs and builds a coconut milk processing tool into Virgin Coconut Oil (VCO) based on the Internet of Things (IoT) with a gradual heating method. The developed system uses a MAX6675 Thermocouple sensor, an ESP32 microcontroller, an electric heater, a 1-phase motor, and a Solid State Relay (SSR) based power supply and controller. The tool is designed to maintain the heating temperature in the range of 60–90 °C with a stability of $\pm 1.5^\circ\text{C}$, and maintains the homogeneity of the coconut milk through an automatic stirring mechanism. IoT integration allows real-time temperature monitoring, so that the production process can be controlled more efficiently, consistently, and

safely compared to traditional methods. The resulting VCO product has clear, odorless, and tasteless characteristics according to general quality standards. However, this research is still limited to the design on a mini plant scale so that trials are needed at industrial production capacity and laboratory testing of VCO quality to ensure compliance with standards. With further development, this tool has the potential to support increasing the added value of coconut products, especially for small and medium industries (SMEs) in coconut-producing areas such as Jambi Province, as well as being a real contribution to the application of IoT technology in the food agro-industry sector based on local potential.

Acknowledgments

We would like to thank the Ministry of Education, Culture, Research, and Technology – Directorate General of Higher Education, Research, and Technology and the Research and Community Service Institute of Jambi Polytechnic Campus for providing support related to research facilities, grant funds, and others.

References

- [1] Daulay, A.R. & Arez, M. 2020. Keberlanjutan kebun kelapa dalam (*Cocos nucifera*) Blok penghasil tinggi di kabupaten tanjung Jabung Timur, Jambi. *Jurnal Analisis Kebijakan Pertanian*, 18(2):151-165
- [2] Badan Pusat Statistik. (2022). Outlook Komoditas Kelapa 2023. Pusat Data dan Sistem Informasi Pertanian, Kementerian Pertanian
- [3] Diba, F.S.W., Jumari & Edan, D.H. 2018. Kelapa Sebagai Komponen Bahan Ramuan Obat di Karaton Ngayogyakarta Hadiningrat dan Pura Pakualaman. *Jurnal penelitian dan pengabdian pelayanan kesehatan*, 2(1):23-28
- [4] Dai, S.I.S. & Asnawi, M.A. 2018. Analisis pengembangan produk turunan kelapa di provinsi Gorontalo. *Frontiers: Jurnal Sains dan Teknologi*, 1(1):17-26
- [5] Berlina, R. 2007. Potensi Kelapa Sebagai Sumber Gizi Alternatif untuk Mengatasi Rawan Pangan. *Buletin Palma*, 32:68-80
- [6] Muharun, M., & Apriyanto, M. 2014. Pengolahan minyak kelapa murni (VCO) Dengan Metode Fermentasi Menggunakan Ragi Tape Merk NKL. *Jurnal Teknologi Pertanian*, 3(2):9-14
- [7] Rahmawati, E. & Khaerunnisya, K. 2018. Pembuatan VCO (Virgin Coconut Oil) dengan Proses Fermentasi dan Enzimatis. *Jurnal of Food and Culinary*, 1(1):1-6
- [8] Dwijayanti, K., Darmawanto, E. & Umam, K. 2018. Penerapan Pengolahan Kelapa Menjadi Minyak Murni (VCO) Menggunakan Teknologi Pemanas Buatan. *Journal of Dedicators Community*, 2(1):27 – 38.
- [9] Santosa, H., Yuliati, Ig., Jaka, M. 2020. Rancang Bangun Alat Sentrifugal Pencuci Daging Buah Kelapa Menggunakan Cairan Air Kelapa (Pre-Processing Metode Sentrifugasi). *Jurnal Metris* 21(1):31-36.
- [10] Antu, M. Y., Maskromo, I. & Rindengan, B. 2020. Potensi daging kelapa kopyor sebagai bahan pangan sehat. *Perspektif Review Penelitian Tanaman Industri*, 19(2):95-104 DOI: 10.21082/psp.v19n2.2020. 95-104
- [11] Tamzil A. 2017. Pembuatan Virgin Coconut Oil (VCO) Dengan Metode Penggaraman. *Jurnal Teknik Kimia*. 23(2):129-136.
- [12] Susilowati. 2009. Pembuatan Virgine Coconut Oil dengan metode penggaraman. *Jurnal Teknik Kimia*, 3(2):246-2
- [13] Pontoh, J., Surbakti, M. & Papolaya, M. 2008. Kualitas virgin coconut oil dari beberapa metode pembuatan. *Chemistry Progress*, 1(1):60-65.
- [14] Lestari, D., Susilo, B. & Yulianingsih, R. 2014. Rancang bangun mesin pemat dan pemerasan santan kelapa portable model kontinyu. *Jurnal Keteknikan Pertanian Tropis Dan Biosistem*, 2(2):117-123.
- [15] Miftahul Walid, Hoiriyah, & Fikri, A. (2022). Pengembangan sistem irigasi pertanian berbasis Internet of Things (IoT). *Jurnal Mnemonic*, 5(1), 23–31.
- [16] Zakiansyah, M., & Sutabri, T. (2025). Integrasi Internet of Things (IoT) dan kecerdasan buatan (AI) untuk smart city di Indonesia. *Jurnal Sains Student Research*, 7(2), 112–120.
- [17] Gubbi, J., Buyya, R., Marusic, S., & Palaniswami, M. (2013). Internet of Things (IoT): A vision, architectural elements, and future directions. *Future Generation Computer Systems*, 29(7), 1645–1660.
- [18] Hidayat, M. F., & Nurhadi, A. (2022). Rancang Bangun Data Logger Multi Kanal Terhubung IoT sebagai Pengukur Temperatur dengan Sensor Thermocouple MAX6675 Type-K. *Emitor: Jurnal Teknik Elektro*, 22(1), 20–26. Universitas Muhammadiyah Surakarta.
- [19] Thoriq, A.; Pratopo, L. H.; Sampurno, R. M.; Shafiyullah, S. H. (2022). Rancang Bangun Sistem Monitoring Suhu dan Kelembaban Tanah Berbasis Internet of Things. *Jurnal Keteknikan Pertanian*, 10(3), 268–280.
- [20] Borrong, R. H., Arifin, Z., & Afma, V. M. (2024). Penggunaan Heater sebagai Alternatif Efektif untuk Pemanas pada Mesin Pengering Ikan dan Kerupuk. *Profisiensi*, 12(2), 77–83. Universitas Riau Kepulauan.
- [21] Yaqin, F. A., Rahmawati, D., Ibadillah, A. F., & Wibisono, K. A. (2021). Perancangan Power Supply Switching dengan Power Factor Correction (PFC) untuk Mengoptimalkan Daya Output dan Pengaman Proteksi Hubung Singkat. *Jurnal Arus Elektro Indonesia*, 7(2), 42–50.
- [22] Zondra, E., Atmam, A., & Yuvendius, H. (2023). Penggunaan Energi Listrik Motor Induksi Satu Fasa Akibat Perubahan Besaran Kapasitor. *SainETIn: Jurnal Sains, Energi, Teknologi, dan Industri*, 4(2), 40-47. Universitas Lancang Kuning Pekanbaru.
- [23] Mazwan, M. (2024). Rancang Bangun Mesin Pengaduk Adonan Roti Turbo. *Jurnal Program Studi Teknik Mesin*, 13(2).
- [24] Adnan R. Al Tahtawi, Erick Andika, dan Wildan Nurfauzan Harjanto, “Desain Awal Pengembangan Sistem Kontrol Irigasi Otomatis Berbasis Node Nirkabel dan Internet-of-Things,” *J.Oto.Ktrl.Inst (J.Auto.Ctrl.Inst)*, vol. 10, no. 2, hlm. 121–132, 2018. ISSN: 2085-2517, e-ISSN: 2460-6340.